

# Auxiliary Relays

## Bistable Fast-Acting Lockout Relay – 7PA22

### Description

7PA22 is a bistable fast-acting auxiliary relay with 8 change-over contacts.

2.1 Due to their quality, reliability, and their structure, these relays are suitable for applications requiring high reliability and availability, as for example power plants, switchgear, railroad systems and industrial plants. Typical examples for this are the petrochemical industry, chemical industry, cement industry, and rolling mills.

The relays comply with IEC, EN, IEEE standards (type testing and routine testing) and bear the CE marking.

The sturdy switch contacts distinguish themselves with a high switching capacity, overload capacity and continuous current capacity which provides perfect insulation. The direct control of high-voltage and medium-voltage systems is possible.

Their high degree of protection and the transparent cover ensure reliable operation under tropical environmental conditions and/or use in salty sea air.

### 7PA22 Fast-Acting Relay with Suppressor Diode

Bistable fast-acting lockout relay with eight change-over contacts, plugged into a flush-mounting frame of type 7XP9010-1 for cabling with screws at the rear, or in an assembly frame of type 7XP9012-0 for cabling with screws at the front.

### Benefits

Tested according to IEC, EN, IEEE standards and bearing the CE marking.

No continuous internal consumption. Position display on the front. Mechanical reset button.

Position memory with two stable positions (for example, open/closed, automatic/manual, local/remote). Mechanically sturdy



[ph\_7PA22\_1, ...]

Figure 2.1/1 Auxiliary Relay 7PA22

contacts, high insulation resistance, high making and breaking power, and a high continuous current enable direct switching in high-voltage and medium-voltage systems. The high degree of protection and the transparent cover ensure absolute reliability during operation within a wide temperature range, and in a tropical or salty environment.

### Applications

The design, quality and high durability of the relays ensure reliable usability under highly demanding conditions such as in power plants, generator stations, transformer stations and railroads. They are suitable for use in energy systems and process control systems for large-scale industry applications, the petrochemical sector, steel and cement factories, and many more.

### Dimensions and Connections

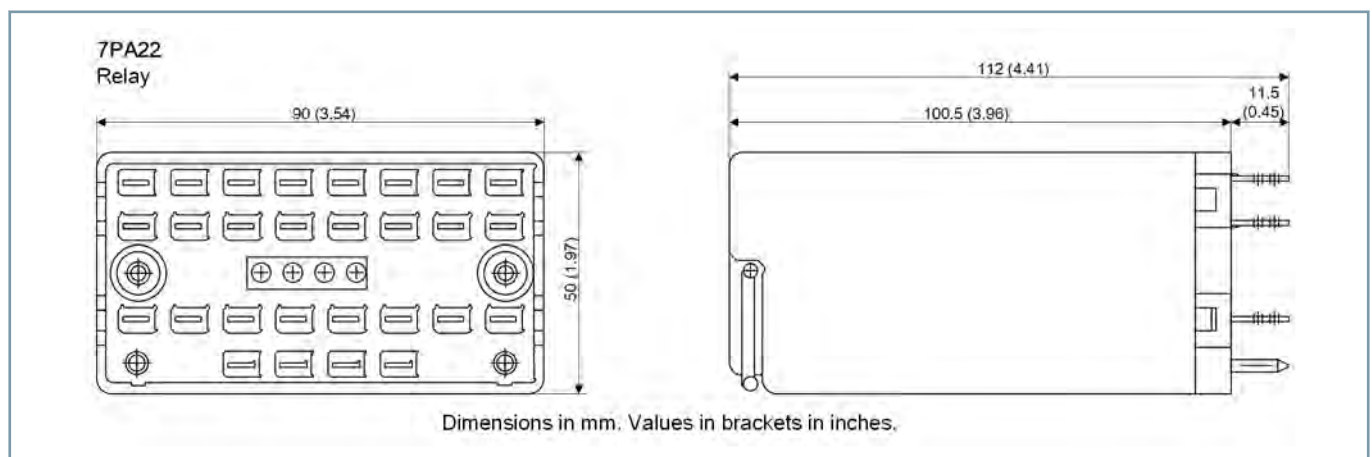

[dw\_7pa22\_dimensions\_and\_panel-mounting-cutout\_2\_en\_US]

Figure 2.1/2 Dimensions and Installation Dimensions

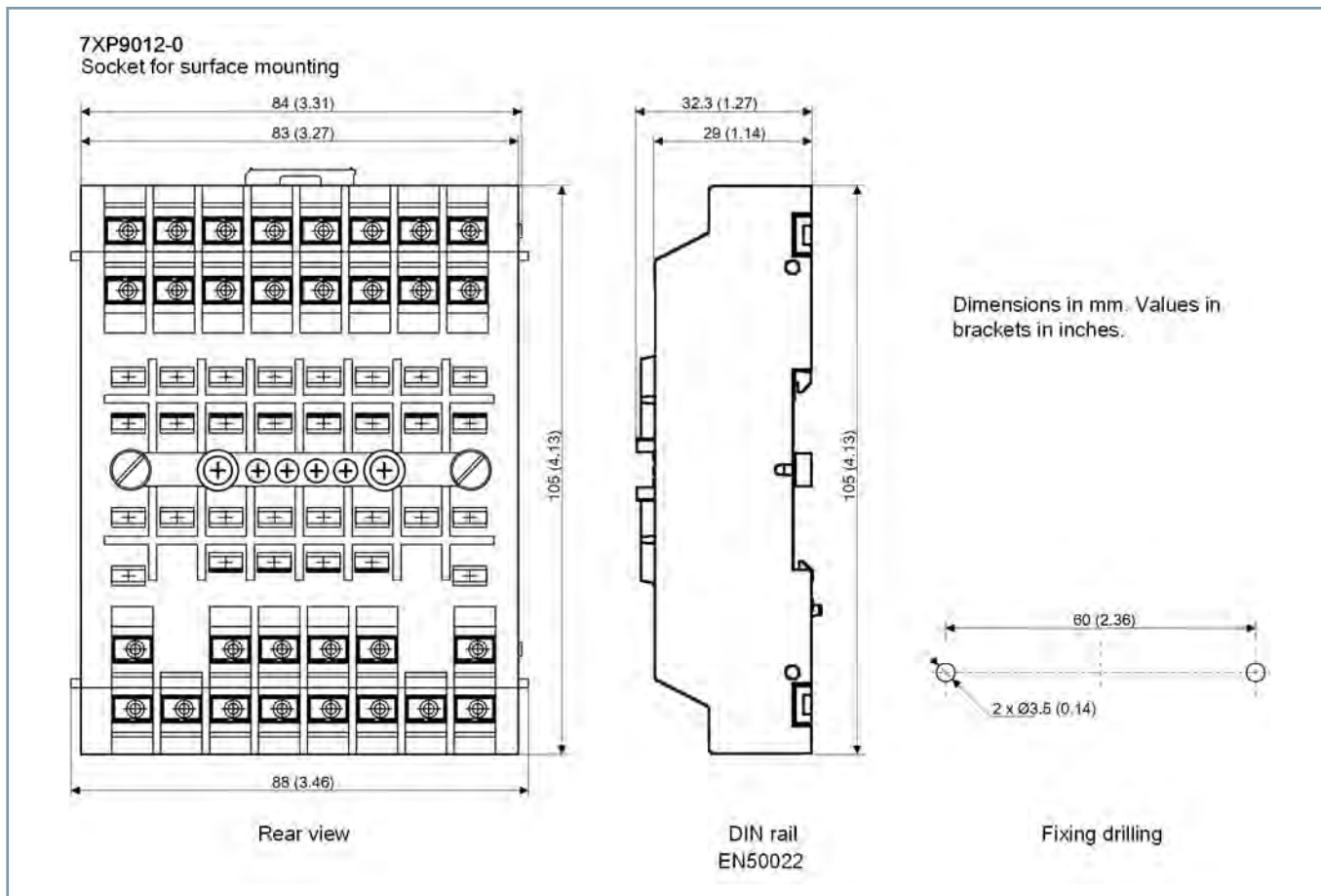

[dw\_7pa22\_socket\_for\_surface-mounting\_2\_en\_US]

Figure 2.1/3 Surface-Mounting Base

# Auxiliary Relays

## Bistable Fast-Acting Lockout Relay – 7PA22

2.1

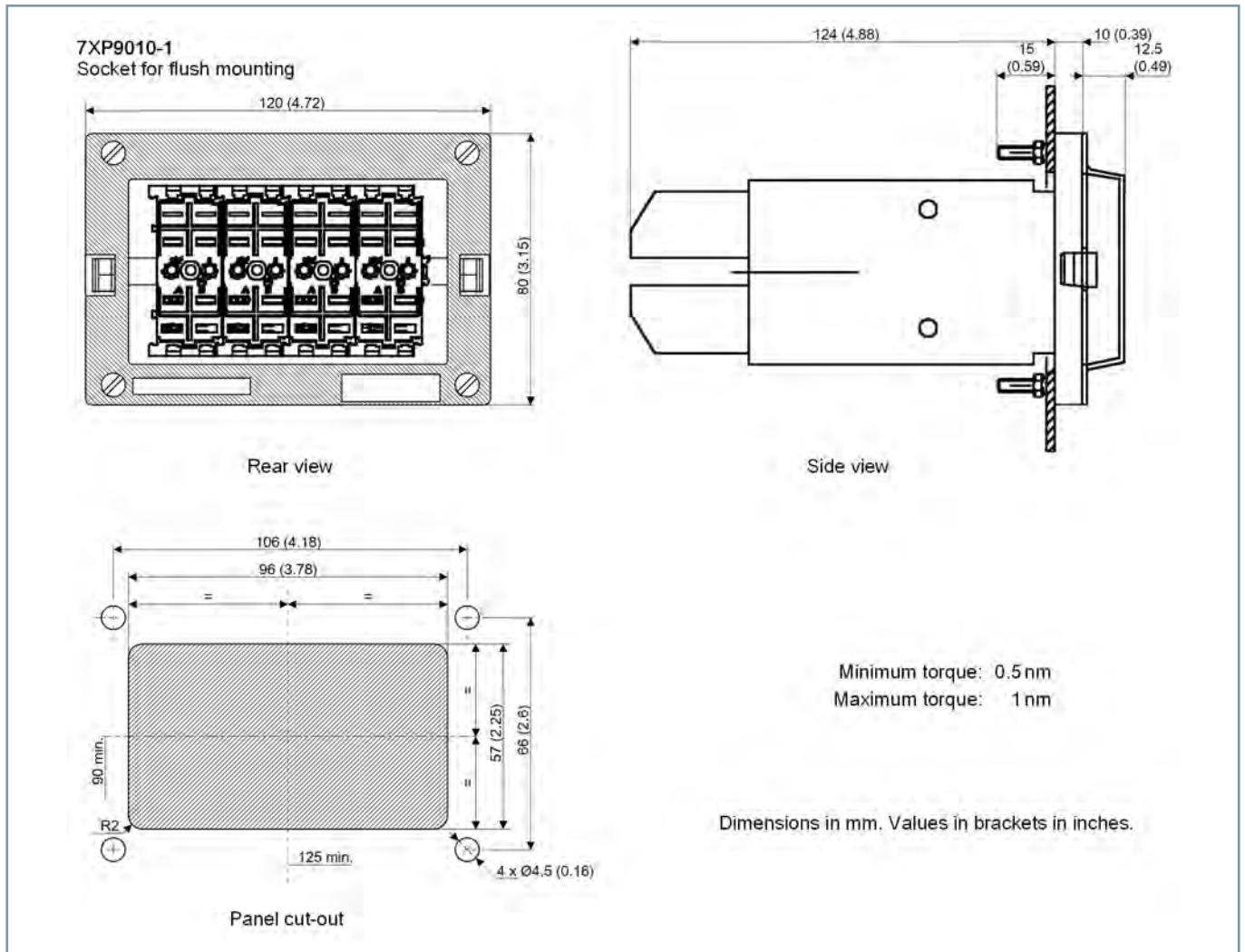

[dw\_7pa22\_socket\_for\_flush-mounting, 2, en\_U5]

Figure 2.1/4 Flush-Mounting Base

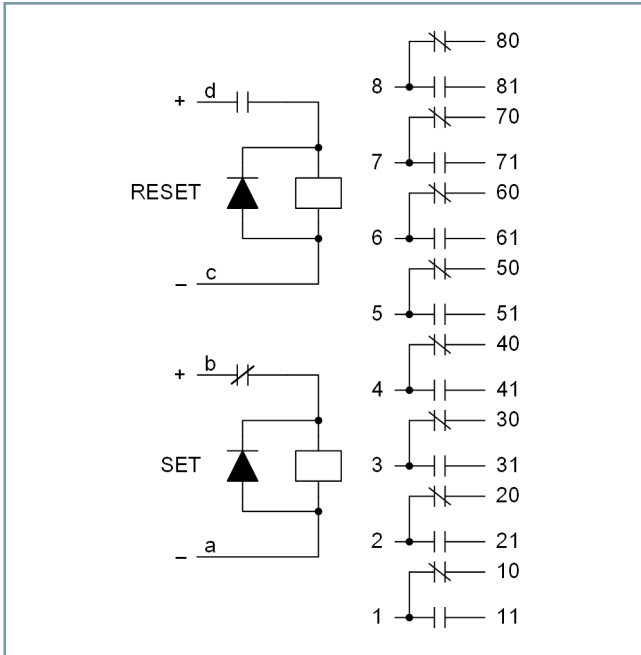

[dw\_7pa22\_connection\_2\_en\_US1]

Figure 2.1/5 Connections 7PA22 – Contacts shown in RESET Position

### Technical Data

The reset button may not be depressed for longer than 20 seconds when the auxiliary voltage is applied to the SET coil.

Breaking power for 10 <sup>5</sup> switching cycles				
220	0.65	1.4	0.28	0.58
For details, refer to diagram				

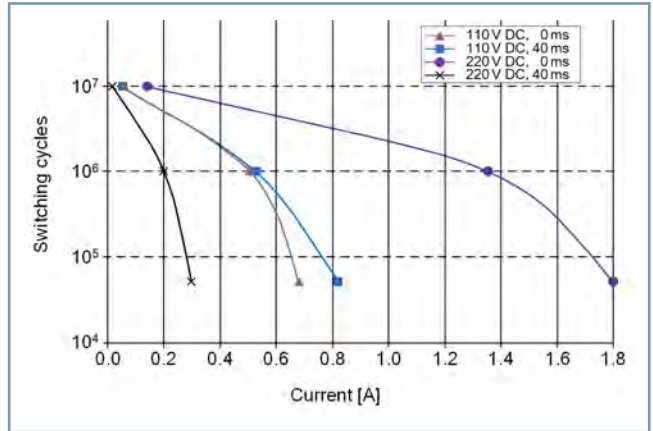

[dw\_7pa22\_curva\_2\_en\_US1]

Figure 2.1/6 Diagram

V <sub>max</sub> , open-circuited contact	250 VDC/400 VAC
Mechanical endurance	10 <sup>7</sup> switching cycles
Operating temperature	-40 °C +70 °C
Max. humidity	93%/40 °C
Seismic load according to IEE501 ZPA	3 g/33 Hz

Rated voltage and internal consumption		
V <sub>N</sub> (VDC)	Voltage range (VDC)	Internal consumption for switching
24	19 to 26	≤45 W
30	24 to 33	
48	38.5 to 53	
60	48 to 66	
110	88 to 121	
125	100 to 137	
220	176 to 242	

Pre-arcing time	< 10 ms
-----------------	---------

Contacts	
Continuous current	10 A
Overload capability	80 A/200 ms 150 A/10 ms
Breaking power	40 A/0.5 s, 110 VDC

Breaking power for 10 <sup>5</sup> switching cycles				
VDC	Not inductive		Inductive, 40 ms	
	1 contact [A]	2 contacts in series [A]	1 contact [A]	2 contacts in series [A]
24	14.5	>20	9.7	>20
48	7.65	>20	3.5	>20
60	5.1	>20	2.3	>20
125	1.2	3.75	0.55	3.75

Design guidelines	
Electrical tests according to	IEC 60255
Insulation	2 kV/50 Hz/1 min
Surge immunity	5 kV/1.2/50 μs
Insulation resistance	> 2000 MOhm/500 VDC
Flame resistance	IEC 60692-2-1
Plastics	UL94: V0 IEC 60695: 850 °C/30 s
Protection class	IEC 60529, EN60529
Relays	IP40
Flush-mounting base	IP10
Surface-Mounting Base	IP10
Environmental conditions	IEC 60255-7
Heat test	IEC 60068-2-2
- Relays in operation	+70 °C/96 h
- Relays not in operation	+55 °C/96 h
Air humidity, cyclical	IEC 60068-2-30: +55 °C/12 h
Cold test, 100 cycles	IEC 60068-2-1
Relays not in operation	-10 °C/2 h
Thermal aging	IEC 60255-7
At rated voltage (V <sub>N</sub> )	55 °C/1440 h

Weights and packaging	
7PA22	600 g
7XP9010	400 g
Carton	150 x 124 x 84 mm

# Auxiliary Relays

## Bistable Fast-Acting Lockout Relay – 7PA22

### Selection and Ordering Data

Description	Order no.															
	1	2	3	4	5	6	7	8	9	10	11	12	13	14	15	16
<b>Bistable fast-acting auxiliary relay with 8 change-over contacts</b>	7	P	A	2	2	□	1	-	□							
						▲			▲							
<i>Rated voltage</i>																
DC 24 V						1										
DC 60 V						2										
DC 110 V						3										
DC 220 V						4										
DC 125 V						5										
DC 30 V						6										
DC 48 V						8										
<i>Base</i>																
Without base									0							
With 7XP9010-1 base									1							
Base as spare part																
Installation	7	X	P	9	0	1	0	-	1							
Surface Mounting	7	X	P	9	0	1	2	-	0							
5 x retaining bracket for auxiliary relay with surface mounting base (1 required for each relay/ surface mounting base)	.	.	.	.	.	.	.	.	.	A	Y	R	:	E	2	9

2.1