

1.1.2.5 7SR17 Motor Protection Relay



Fig 1. 7SR17 Rho Fascia

Description

The 7SR17 motor protection relay range utilises service and design experience accumulated with the previous generations of Rho family of products. Housed in 4U high, size E4 or E6 cases the 7SR17 Rho can provide protection, control, monitoring, instrumentation and metering with integrated input and output logic, data logging and fault reports. Relay functionality is accessed via a familiar user friendly interface. Communication access to relay functionality is via a front USB port for local PC connection, rear RS485 port for remote connection or optional IEC61850 communication through two rear Ethernet ports (Electrical or Optical).

Function Overview

Protection (can include)

14	Stall Protection
46	Phase Unbalance Protection
49	Thermal Overload
48/66	Start Protection
37	Undercurrent
67/50, 67/51	Directional Overcurrent
67G/67N	Directional Earth Fault
87REF	High Impedance REF
27/59	Under/Over Voltage
47	NPS Voltage/Phase Reversal
81	Under/Over Frequency
32	Power
32S	Sensitive Power
55	Power Factor

Supervision (can include)

46PhRev	Phase Reversal
50BCL	Breaking Capacity Limit
50BF	Circuit Breaker Fail
60CTS-I	CT Supervision
60CTS	Enhanced CT Supervision
60VTS	VT Supervision
74T/CCS	Trip Circuit Supervision
81B	Anti Backspin
Temp	Temperature Input Monitoring

Control (can include)

86 Lockout
 Motor Start/Stop Control
 User Programmable Logic

Features

4 Settings Groups
 Password Protection – 2 levels (protection and control)
 Self Monitoring

User Interface

20 character x 4 line backlit LCD
 Menu navigation keys
 9 Programmable Tri-colour LEDs

Monitoring Functions

Monitoring Functionality (can include)

Phase, earth and sequence currents
 Thermal equivalent and phase difference currents
 Line, phase, neutral and sequence voltages
 Power - Apparent, Real and Reactive. Power factor
 Energy - WHr and VAr Hr
 Demand metering
 Start/Run Monitoring Profiles:
 Number of Starts, Starts per hour
 Start currents, voltages and power
 Start method (Local/remote/comms)
 Motor run / start / trip times, thermal status,
 Binary Input / Output status
 General Alarms inc. trip circuit healthy/failure
 Starters
 Fault data
 CB trip and maintenance counters and Time to Trip
 Temperature input (optional) values

Description of Functionality

With reference to figure 4 'Function Diagrams'.

14 Stall Protection

Each element has a single definite time overcurrent characteristic with settings for pickup level and Definite Time Lag (DTL) delays. Operation can be controlled from motor stopped or running conditions.

37 Undercurrent

Each element has settings for the pickup level and the definite time lag (DTL) delay. The element operates when current falls below setting for the duration of the delay.

46 Phase Unbalance Protection

Unbalance current has a significant heating effect on the motor. Two phase unbalance measurement modes are available. Either NPS current or the difference between maximum and minimum phase currents can be used as a measurement of the unbalance level. Inverse or definite time operation can be selected.

48/66 Start Protection

The feature provides settings to control both the number of times a motor can be started within a specified time period and the minimum time between starts. Motor starting can be inhibited when this limit is reached. Motor start time can also be monitored.

49 Thermal Protection – Rotating Plant

The enhanced thermal algorithm provides compliance with IEC60255-8 (Thermal Electrical relays). The operating curves take into account the effects of present loading, prior loading and unbalanced currents on the motor operating temperature. A user definable thermal curve is selectable to allow matching of the relay thermal characteristic to all motor and cooling system types. 'Starting' and 'cooling' constants modify the thermal characteristic during motor run-up and stopped conditions.

Temperature Inputs

Motor resistance temperature detectors (RTDs) can be connected via an optional external 7XV5662-6AD10 Temperature Monitoring Interface. Up to twelve Pt100 sensors can be monitored. The interface is connected to the COM1-RS485 port of the relay.

50/51, G/N Earth Fault

Two earth fault measurement modes are available. Measured earth fault mode (G) directly measures the earth current from an independent CT, or the residual connection of the 3 line CT's. Derived earth fault mode (N) derives the earth current internally from the line CT inputs. Independent settings are available for pickup current and time-delays. IDMT curves are available.

50/51 Overcurrent

Definite time elements provide short circuit overcurrent protection with independent settings for pickup current and time-delays. IDMT curves can also be selected.

50BF Circuit Breaker Fail

The circuit breaker fail function may be triggered from an internal trip signal or from a binary input. Where a CB closed is detected following a trip signal an output is issued after a specified time interval. This can be used to re-trip the CB or to back-trip an upstream CB. A second time delay is available to enable another stage to be utilized if required.

60CTS CT Supervision

Two types of CT wiring monitoring is available dependent on the availability of VT inputs: 60CTS-I determines CT failure from a comparison of phase current levels. Where VT inputs are available 60CTS considers the presence of negative phase sequence current, without an equivalent level of negative phase sequence voltage. The element has user operate and delay settings.

81B Anti Backspin

To inhibit attempted restarting of the motor until after the rotor has completely stopped backspin protection is applied. Starting is inhibited until the 81B time delay has elapsed.

87REF High Impedance REF

The 87REF function can provide high speed earth fault protection for motor winding faults. This function requires an external series stabilising resistor and voltage limiting non-linear resistor.

74TCS Trip Circuit Supervision

The trip circuits can be monitored via binary inputs connected in H4/H5/H6 or H7 schemes. Trip circuit failure raises an HMI alarm and output(s).

Programmable User Logic

The user can map Binary Inputs and Protection operated outputs to Function Inhibits, Logic Inputs, LEDs and/or Binary Outputs. The user can also enter up to 4 equations defining scheme logic using standard functions e.g. Timers, AND/OR gates, Inverters and Counters. Each Protection element output can be used for Alarm/Indication and/or tripping.

Function LED's

Ten user programmable tri-colour LED's are provided eliminating the need for separate panel mounted indicators and associated wiring. Each LED can be user set to red, green or yellow allowing for indication of the associated function's status. A slip-in pocket adjacent to the LEDs enables the user to insert customised labels. A printer compatible template is available.

Optional Functionality

27/59 Under/Over Voltage

Each element has settings for pickup level, drop-off level and Definite Time Lag (DTL) delayed operation. The elements can be independently selected to under or over voltage operation.

32 Power

This feature can be used to detect loss of motor load. Each element can be set to measure real, apparent or reactive power and has independent settings for pickup level and Definite Time Lag (DTL) delayed operation.

32S Sensitive Power

Sensitive power is measured from the 4th CT input (IG) and user selected voltage inputs. Each element can be set to measure real, apparent or reactive power and has independent settings for pickup level and Definite Time Lag (DTL) delayed operation.

47 Negative Phase Sequence (NPS) Overvoltage

Unbalance (NPS) voltage can be caused by uneven system loading. Each element has independent settings for pickup level and Definite Time Lag (DTL) delayed operation.

49TS Integral Temperature Sensor Inputs

4 or 8 Temperature Sensors can be connected to the optional integral temperature sensor inputs. RTD or thermistor sensors can be used. All sensors must be of the same type.

55 Power factor

This feature is used to monitor motor operating conditions.

Each element has independent settings for pickup level and Definite Time Lag (DTL) delayed operation.

60VTS VT Supervision

The VT Supervision uses a combination of sequence component voltage and current to detect a VT fuse failure. This condition can provide an output for indications/alarms or used to inhibit voltage dependent functions. Element has user operate and delay settings.

67 Directional Control for Overcurrent and Earth Fault

Directional control can be used to provide additional protection discrimination e.g. correct discrimination for earth faults in non-effectively earthed systems with appreciable capacitance.

81 Under/Over Frequency

Frequency elements can be used to monitor supply quality e.g. under-frequency causing motor deceleration. Each element has independent settings for pickup level, drop-off level and Definite Time Lag (DTL) delayed operation.

Thermistor	100Ω – 40KΩ	± 2% or ± 5Ω
------------	-------------	--------------

Auxiliary supply

Nominal voltage	Operating Range V
24 to 60V dc	18 to 72V dc
80 to 250V dc	64 to 300V dc
115V ac	92 to 138V ac
24 to 250 V dc	19.2 to 275 V dc
100 to 230 V ac	80 – 253V ac
Allowable superimposed ac component	12% of DC voltage
Allowable breaks/dips in supply (collapse to zero)	50ms (DC) 2.5/3 cycles (AC)

Auxiliary supply: Burdens

Power Consumption	Min (DC)	3.9W (6W with IEC61850)
	Max (DC)	8W (10.1W with IEC61850)
	Min (AC)	9VA (14.5VA with IEC61850)
	Max (AC)	15VA (20.5VA with IEC61850)

Binary Inputs

Operating Voltage	19V: Range 17 to 320V dc 19V: Range 92 to 138 V ac 88V: Range 74 to 320V dc
Maximum current for operation	1.5mA dc 1.5mA peak ac

Binary Outputs

Operating Voltage	Voltage Free
Operating Mode	User selectable - Self or Hand Reset
Contact Operate / Release Time.	7ms / 3ms
Making Capacity: Carry continuously Make and carry (L/R ≤ 40 ms and V ≤ 300 V)	5A ac or dc 20A ac or dc for 0.5s 30A ac or dc for 0.2s
Breaking Capacity (≤ 5 A and ≤ 300 V): AC Resistive AC Inductive DC Resistive DC Inductive	1250VA 250VA at PF ≤ 0.4 75W 30W at L/R ≤ 40ms 50W at L/R ≤ 10ms

Technical Data

For full technical data refer to the Performance Specification Section of the Technical Manual.

Inputs and Outputs

Current Inputs

Quantity	3 x Phase, 1 x SEF
Rated Current IN	1/5A
Measuring Range	Phase: 80 xIn SEF: 10 xIn
Instrumentation 10% to 200% In	±1% or ±1% In
Frequency	50/60Hz
Thermal Withstand: Continuous 1 Second	4.0 x In 100A (1A) 350A (5A)
Burden @ In	≤0.1VA (1A Phase and SEF) ≤0.3VA (5A Phase and SEF)

Voltage Inputs

Quantity	3 (Optional)
Rated Voltage Vn	40 – 160V
Instrumentation 10% to 200% Vn	±1% or ±1% Vn
Frequency	50/60Hz
Thermal Withstand: Continuous	300V rms
Burden @ 110V	≤0.6VA

Temperature Detector Inputs

Value	Reference	Accuracy
RTD	Cu10, 0 – 540°C	± 3°C (0 – 250°C)
	Ni100, 0 – 400°C	± 1°C (0 – 250°C)
	Ni120, 0 – 330°C	
	Ni250, 0 – 535°C	
	Pt100, 0 – 540°C	
	Pt250, 0 – 540°C	
Pt1000, 0 – 260°C	± 2°C (0 – 250°C)	

Data Communication Interface

Communication Port	Front USB Type B Rear RS485 2 wire electrical IEC61850 optional ports: 2x Electrical RJ45 Ethernet 2x LC Fibre Optic Ethernet
Fibre Optic Ethernet Data Communication Interface (IEC 61850 Option)	

EN100 Fibre Optic Data Communication Interface (IEC 61850 Option)

Physical Layer	Fibre-optic
Connectors	Duplex LC 100BaseF in acc. With IEEE802.3

Recommended fibre	62.5/125 µm glass fibre with Duplex-LC connector
Transmission Speed	100 Mbits/s
Optical Wavelength	1300 nm
Bridgeable distance	2 km

EN100 Electrical Ethernet Data Communication Interface (IEC 61850 Option)

Physical Layer	Electrical
Connectors	RJ45 100BaseF in acc. With IEEE802.3
Recommended cable	Minimum: Category 5 S/FTP (shielded/screened twisted pair)
Transmission Speed	100 Mbits/s
Test Voltage (with regard to socket)	500 VAC 50 Hz
Bridgeable distance	20m

Mechanical Tests

Vibration (Sinusoidal) IEC 60255-21-1 Class I

Type	Level	Variation
Vibration response	0.5gn	≤ 5 %
Vibration endurance	1.0gn	≤ 5 %

Shock and Bump IEC 60255-21-2 Class I

Type	Level	Variation
Shock response	5gn, 11 ms	≤ 5 %
Shock withstand	15gn, 11ms	≤ 5 %
Bump test	10gn, 16ms	≤ 5 %

Seismic IEC 60255-21-3 Class I

Type	Level	Variation
Seismic response	1gn	≤ 5 %

Mechanical Classification

Durability	>10 ⁶ operations
------------	-----------------------------

Electrical Tests

Insulation IEC 60255-5

Type	Level
Between any terminal and earth	2.0kV AC RMS for 1min
Between independent circuits	
Across normally open contacts	1.0kV AC RMS for 1min

High Frequency Disturbance IEC 60255-22-1 Class III

Type	Level	Variation
Case, Aux Power & I/O. Common mode	2.5kV	≤ 10%
Case, Aux Power & I/O. Transverse mode	1.0kV	≤ 10%
RS485 Comms	1.0kV	No data loss

Electrostatic Discharge IEC 60255-22-2

Type	Level	Variation
Front Cover Fitted	Class IV, 15 kV Air Discharge	≤ 5 %
Front Cover Removed	Class III, 8 kV Air Discharge	≤ 5 %

Electrical Fast Transient / Burst Immunity IEC 60255-22-4 Class A (2002)

Type	Level	Variation
Case, Aux Power & I/O	4.0kV	≤ 10%
RS485 Comms	2.0kV	No data loss

Surge Immunity IEC 60255-22-5

Type	Level	Variation
Analog Inputs. Line to Earth	4.0kV	≤ 10%
Case, Aux Power & I/O. Line to Earth	2.0kV	
Analog Inputs. Line to Line	1.0kV	
Case, Aux Power & I/O. Line to Line	1.0kV*	
RS485 Comms port. Line to Earth	1.0kV	No data loss

*Note 50ms pick up delay applied to binary inputs

Conducted Radio Frequency Interference IEC 60255-22-6

Type	Level	Variation
0.15 to 80MHz	10V	≤ 5%

Radiated Radio Frequency IEC 60255-25

Type	Limits at 10m, Quasi-peak
30 to 230MHz	40dB(µV/m)
230 to 10000MHz	47dB(µV/m)

Conducted Radio Frequency

Type	Limits	
	Quasi-peak	Average
0.15 to 0.5MHz	79dB(µV)	66dB(µV)
0.5 to 30MHz	73dB(µV)	60dB(µV)

Radiated Immunity IEC 60255-22-3 Class III

Type	Level	Variation
80MHz to 1000MHz	10V/m	≤ 5%

Magnetic Field with Power Frequency IEC 61000-4-8, Class V

Type	Level
100A/m (0.126mT) continuous	50Hz
1000A/m (1.26mT) for 3s	

Environmental Tests

Temperature IEC 60068-2-1/2

Operating Range	-10°C to +55°C
Storage range	-25°C to +70°C

Humidity IEC 60068-2-78

Operational test	56 days at 40°C and 93% relative humidity
------------------	-------------------------------------------

Cyclic Temperature and Humidity IEC 60068-2-30

Operational test	25 °C to 55 °C (outdoor equipment) and 97/93 % relative humidity. 6 x 24h (12h+12h) cycles.
------------------	---------------------------------------------------------------------------------------------

IP Ratings IEC 60529

Type	Level
Installed with cover	IP 51 from front of relay
Installed with cover removed	IP 20 from front of relay

For full technical data refer to the Performance Specification Section of the Technical Manual.

Performance

14 Stall Protection

Number of Elements	4
Setting Range Is: -	0.05 to 10 x In
Time Delay	0.00 to 14400s
Operate Level	100% Is ±5% or ±1% xIn
Operate time	
2 x Is	35ms ± 10ms,
5 x Is	25ms ± 10ms
Operate time following delay	t _{basic} + t _d , ±1% or ±10ms
Controlled by	Stopped, No acceleration, Running, None

27/59 Under/Over Voltage

Number of Elements	4 Under or Over
Operate	Any or All phases
U/V Guard	1 to 200V
Setting Range Vs	5 to 200V
Hysteresis Setting	0 to 80%
Operate Level Vop	100% Vs ±1% or ±0.25V
Reset Level: -	
Undervoltage	(100% + hyst) x Vop ±1% or ±0.25V
Overvoltage	(100% - hyst) x Vop ±1% or ±0.25V
Delay Setting td	0 to 14400s
Basic Operate Time: -	
1.1xVs (OV)	73ms ±10ms
2.0xVs (OV)	63ms ±10ms
0.5xVs (UV)	58ms ±10ms
Operate time following delay.	t _{basic} + t _d , ±1% or ±10ms
Inhibited by	Binary or Virtual Input VT Supervision, Voltage Guard

32 Power

Number of Elements	2 Forward or Reverse
Operate	P, Q or S
U/C Guard	0.05 to 1.0 x In
Setting Range Ss	0.05 to 2.0 x Sn
Operate Level Sop	100% Ss, ± 5% or ± 2% Sn
Reset Level: -	≥95% Sop
Basic Operate Time: -	
1.1 x Ss (over)	60ms ± 10ms
2.0 x Ss (over)	45ms ± 10ms

0.5 x Ss (under)	40ms ± 10ms
Delay Setting td	0 to 14400s
Operate time following delay.	t _{basic} + t _d , ±1% or ±10ms
Inhibited by	Motor not running, VTS

32S Sensitive Power

Number of Elements	2 Forward or Reverse
Operate	P, Q or S
U/C Guard	0.005 to 1.0 x In
Setting Range Ss	0.005 to 2.0 x Sn
Operate Level	100% Ss ± 5% or ± 2% Sn
Reset Level: -	≥95% Sop
Basic Operate Time: -	
1.1 x Ss (over)	60ms ± 10ms
2.0 x Ss (over)	45ms ± 10ms
0.5 x Ss (under)	30ms ± 10ms
Delay Setting td	0 to 14400s
Operate time following delay.	t _{basic} + t _d ± 1% or ± 10ms
Inhibited by	Motor not running, VTS

37 Undercurrent

Number of Elements	2
U/C Guard	0.05 to 5.0 x In
Setting Range Is	0.05 to 5.0 x In
Operate Level	100% Is ± 5% or ± 1% xIn
Delay Setting td	0 to 14400s
Basic Operate Time: -	
0.5 x Is	50ms ± 10ms
Operate time following delay.	t _{basic} + t _d , ± 1% or ± 10ms
Overshoot Time	< 40ms
Inhibited by	Binary or Virtual Input

46 Phase Unbalance Protection

Number of Elements	1 (Magnitude difference or NPS)
Setting Range Is	0.1 to 0.4 x Itheta
Operate Level	100% Is ± 5% or ± 1% x In
IT Min. Operate Time	0 to 20s
DT Delay Setting td	0 to 20s
Basic Operate (Magnitude Difference)	
2 x Is	55ms ± 10ms
5 x Is	50ms ± 10ms
Basic Operate (NPS)	
2 x Is	70ms ± 10ms
5 x Is	60ms ± 10ms
DT Operate time following delay.	t _d ± 1% or ± 30ms
Tm Time Multiplier	0.025 to 2.0
Overshoot Time	< 40ms
Inhibited by	Binary or Virtual Input

47 Negative Phase Sequence Voltage

Number of Elements	2
Setting Range Vs	1 to 90V
Hysteresis Setting	0 to 80%
Operate Level	100% Vs ± 2% or ± 0.5V
Delay Setting td	0 to 14400s
Basic Operate Time: -	
2 x Vs	80ms ± 20ms
10 x Vs	55ms ± 20ms
Operate time following delay.	t _{basic} + t _d ± 2% or ± 20ms
Overshoot Time	< 40ms
Inhibited by	Binary or Virtual Input

48/66 Start Protection

Max. No. of Starts	OFF, 1 to 20
Max. Starts Period	1 to 60 minutes
Start Inhibit Delay	1 to 60 minutes
Time Between Starts	OFF, 1 to 60 minutes

49 Thermal Protection

Setting Range Itheta	0.1 to 3.0 x In
NPS Weighting Factor (K)	0.1 to 10.0 Δ 0.1
TauH Heating Constant	0.5 to 1000 mins, Δ 0.5 mins
TauS Starting Constant	0.005 to 1.0 x TauH, Δ 0.005
TauC Cooling Constant	1 to 100 x TauH, Δ 1
Hot/cold ratio	OFF, 1 to 100%, Δ 1%
Operate Level	100% Is, ±5% or ±1% x In
Operate time	$t = \tau \times In \left[\frac{I_{EQ}^2 - \left(1 - \frac{H}{C}\right) I_p^2}{I_{EQ}^2 - I_o^2} \right]$ ±5% or ±100ms (Itheta = 0.3 to 3 x In) (1.2 to 20 x Itheta) User defined
Capacity Alarm Level	Disabled, 50,51...100%
Load Alarm Level	OFF, 0.5 to 1.0 x Itheta, Δ 0.05
Thermal restart inhibit	20 to 100%, Δ 1%
Inhibited by	Binary or Virtual Input

50 (67) Instantaneous/DTL OC & EF

Operation 7SR17n2/3 7SR17n5/6	Non directional. Non directional, Forward or reverse
Elements	Phase, Derived Earth, Measured Earth
Setting Range Is: - O/C '50' Derived E/F '50N' Measured E/F '50G'	0.05 to 50 x In 0.05 to 50 x In 0.005 to 5 x In
Time Delay	0.00...14400s
Operate Level	100% Is ± 5% or ± 1% x In
Operate time: 50 50N	0 to 2xIs – 35ms, ±10ms, 0 to 5xIs – 25ms, ±10ms 0 to 2xIs – 40ms, ±10ms, 0 to 5xIs – 30ms, ±10ms
Operate time following delay	t _{basic} + t _d , ±1% or ±10ms
Inhibited by	Binary or Virtual Input Inrush detector VT Supervision

51 (67) Time Delayed OC&EF

Operation 7SR17n2/3 7SR17n5/6	Non directional. Non directional, Forward or reverse
Elements	Phase, Derived Earth, Measured Earth
Characteristic	IEC: NI,VI,EI,LTI ANSI: MI,VI,EI DTL
Setting Range Is	0.05 to 2.5 x In (OC, N) 0.005 to 0.5 x In (G)
Time Multiplier (IEC/ANSI)	0.025 to 100
Time Delay	0 to 20s
Operate Level	105% Is ± 4% or ± 1% x In

Minimum Operate time IEC	$t_{op} = \frac{K}{\left[\frac{I}{I_n}\right]^\alpha - 1} \times T_m$
ANSI	$t_{op} = \left[\frac{A}{\left[\frac{I}{I_n}\right]^\alpha - 1} + B \right] \times T_m$ ± 5% or ± 30 ms
Follower Delay	0 - 20s
Reset	ANSI decaying, 0 – 60s
Inhibited by	Binary or Virtual Input VT Supervision

50BF Circuit Breaker Fail

Operation	Current check - Phase and Measured Earth with independent settings, Mechanical Trip, CB Faulty Monitor
Setting Range Is	0.05 to 2 x In (50BF) 0.005 to 2 x In (50BF-I4)
2 Stage Time Delays	Timer 1: 0.02 to 60s Timer 2: 0.02 to 60s
Operate Level	100% Is ± 5% or ± 1% x In
Basic Operate time	< 20ms
Operate time following delay	t _{delay} ± 1% or ± 20ms
Triggered by	Any function mapped as trip contact.
Inhibited by	Binary/Virtual Input
Timer By pass	Yes, 50BF CB Faulty Input

55 Power factor

Number of Elements	2
Operation	Under or Over
U/C Guard	0.05 to 1.0
Setting Range PFs	0.05 to 0.99
Time Delays	0 to 14400s
Operate Level	± 0.05
Basic Operate time	≤ 80ms
Operate time following delay	t _{basic} + t _d ± 1% or ± 10ms
Inhibited by	Motor not running, VTS

81 Under/Over Frequency

Number of Elements	2 Under or Over
U/V Guard	35 to 200V
Setting Range Fs	43 to 68Hz
Hysteresis Setting	0 to 2%
Operate Level Fop	100% Fs ± 10mHz
Reset Level: - Under Frequency Over Frequency	(100% + hyst) x Fop ± 10mHz (100% - hyst) x Fop ± 10mHz
Delay Setting t _d	0 to 14400s
Basic Operate Time: - For ROCOF between 0.1 and 5Hz/second	Typically < 110ms Maximum < 150ms
Operate time following delay.	t _{basic} + t _d ± 1% or ± 10ms
Inhibited by	Binary or Virtual Input, Voltage Guard

87REF Restricted Earth Fault

Setting Range Is	0.005 to 2.0 x In
Operate Level	100% Is ± 5% or ± 1% x In
Time Delay	0 to 60s
Basic Operate Time 2 x Is 5 x Is	40ms ± 10ms 30ms ± 10ms
Inhibited by	Binary or Virtual Input

7SR17 Rho Connection Diagram

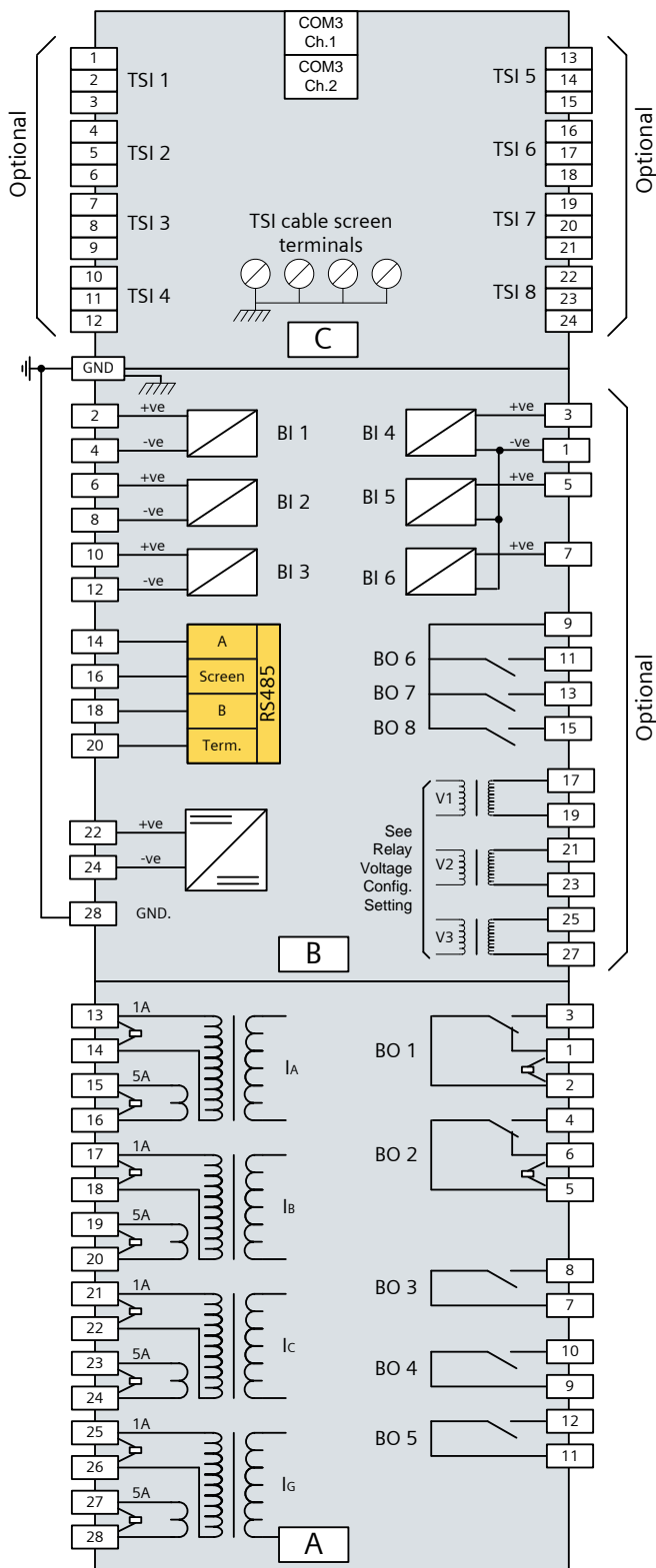

RTD or Thermistor Connections (shown for Temperature Sensor Inputs (TSI) 1-4):-

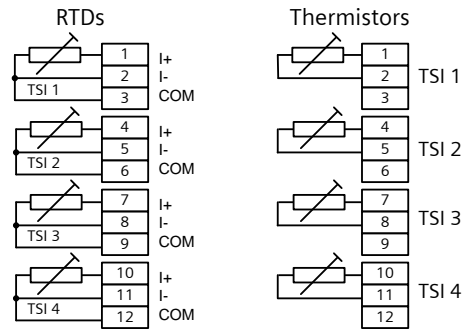

Screened cable is recommended for use with the optional temperature inputs. Four earth screw terminals are provided on the rear of the relay for cable screens.

Relay Earthing

Terminal 28 of the Power Supply Unit should be earthed by a direct connection to the relay case earth stud.

The relay case earth stud should be solidly earthed by a direct connection to the panel earth.

BI = Binary Input,
BO = Binary Output
GND = Ground/earth
TSI = Temperature Sensor Input

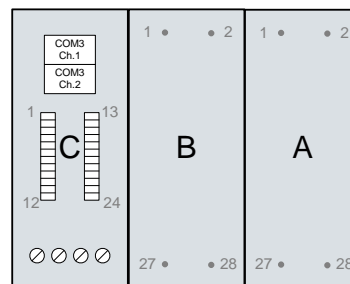
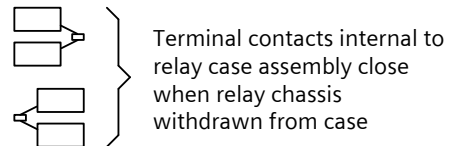
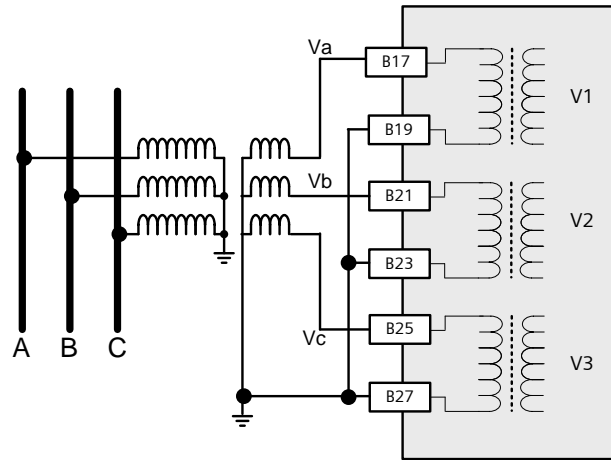

Fig2. 7SR17 Rho Wiring Diagram

Relay Voltage Configuration Setting

VT Wiring Connections

V_{an}, V_{bn}, V_{cn}



V_a, V_b, V_c

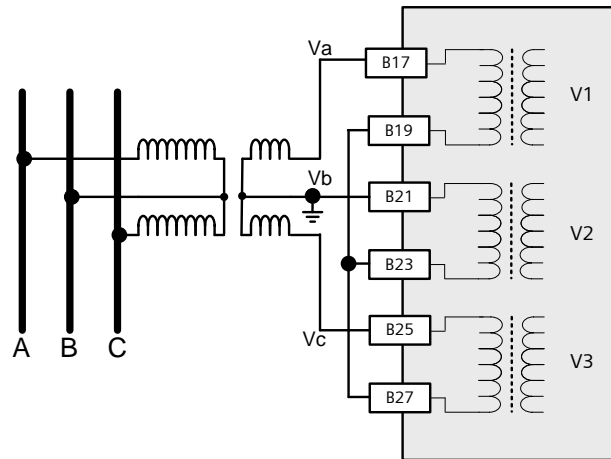

$V_{ab}, V_{bc}, 3V_0$

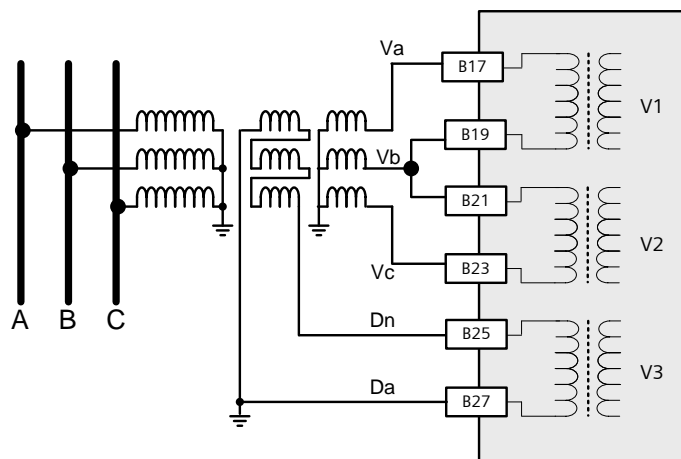

Fig3. 7SR17 Rho VT Wiring Connections

7SR17 Rho Function Diagram

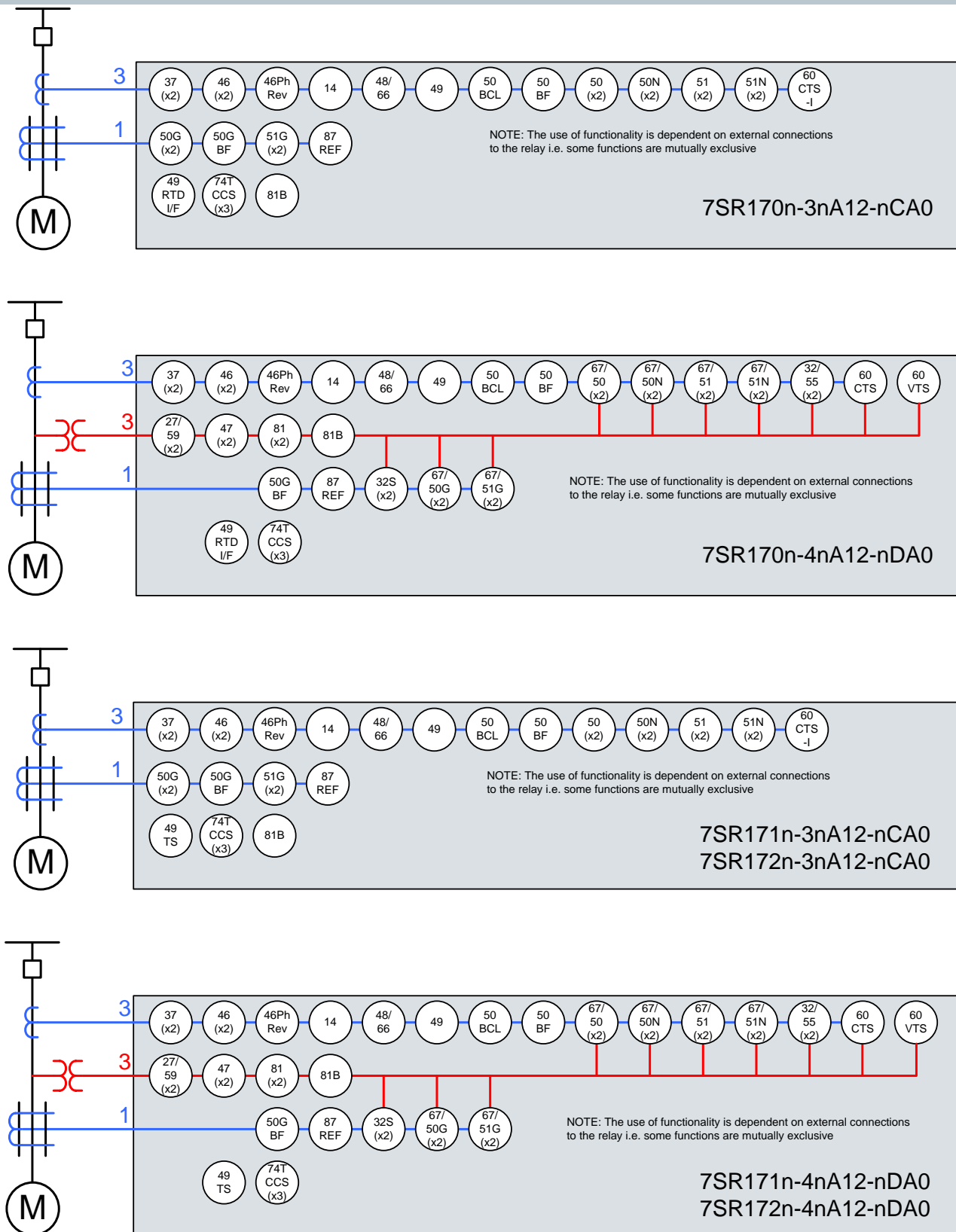

Fig4. Function Diagrams - 7SR17 Relays

Ordering Information – 7SR17 Rho Motor Protection Relay

ORDER-No.:

1	2	3	4	5	6	7	8	9	10	11	12	13	14	15	16
7	S	R	1	7					A				C	A	0

Protection Product Family

Motor Protection	5															
	7															

Relay Type

Basic Relay (See Note 1)	6															
Relay with 4 Temperature inputs (See Note 1)	0															
Relay with 8 Temperature inputs (See Note 1)	1							M/N								
	2							M/N								

Case, I/O and Fascia

4 CT, 3 Binary Inputs / 5 Binary Outputs, 10 LEDs	7															
4 CT, 6 Binary Inputs / 8 Binary Outputs, 10 LEDs	2															
4 CT, 3 VT, 3 Binary Inputs / 5 Binary Outputs, 10 LEDs	3															
4 CT, 3 VT, 6 Binary Inputs / 8 Binary Outputs, 10 LEDs	5															
	6															

Measuring input

1/5 A, 50/60Hz with SEF Input	8															
1/5 A, 40-160V, 50/60Hz with SEF Input	2/3															
	3															
	4															

Auxiliary voltage

80-250V DC / 115V AC, binary input threshold 19V DC	9															
80-250V DC, binary input threshold 88V DC	G															
24-60V DC, binary input threshold 19V DC	H															
PSU Rated: 24-250V DC / 100-230V AC. Binary Input threshold 19V DC (Rated: 24-250V DC / 100-120V AC)	J															
PSU Rated: 24-250V DC / 100-230V AC. Binary Input threshold 88V DC (Rated: 110-250V DC)	M															
	N															

Additional Options

Standard relay	10															
	A															

Communication Interface

Standard version - included in all models, USB front port, RS485 rear port (See Note 1)	11															
Standard version - plus additional rear electrical Ethernet RJ45 (x2) (See Note 1)	1															
Standard version - plus additional rear optical Ethernet duplex (x2) (See Note 1)	7							M/N								
	8							M/N								

Protocol

IEC 60870-5-103, Modbus RTU, DNP 3.0 (user selectable). Also Modbus RTD Client (see Note 2)	12															
IEC 60870-5-103, Modbus RTU, DNP 3.0 (user selectable) and IEC61850. Also Modbus RTD Client (see Note 2)	2															
	7/8															
	7															

Front Cover

Standard Version - No Push Buttons	13															
Push Buttons - DOWN and RIGHT Arrows	1															
	2															

Ordering Information – 7SR17 Rho Motor Protection Relay

ORDER-No.:

1	2	3	4	5	6	7	8	9	10	11	12	13	14	15	16	
7	S	R	1	7			-			A			-	C	A	0

Protection Function Packages

For future development		14	A
For future development			B
Standard version - included in all models			C
14	Stall Protection		
37	Undercurrent		
46	Phase Unbalance		
46PhRev	Phase Reversal		
48/66	Start Protection		
49	Thermal overload		
49 RTD I/F (See Note 2)	RTD Monitoring via comms		
50/51	Overcurrent		
50/51, G/N	Earth fault		
50BF	Circuit breaker fail		
50BCL	Break Capacity Limit		
60CTS-I	CT Supervision		
74T/CCS	Trip/Close Circuit Supervision		
81B	Backspin Protection		
87REF	High Impedance Restricted Earth Fault		
	Programmable Logic		
For variants with Temperature inputs			
49 Temp	Temperature Input monitoring		
For variants with 3 x VT inputs as above - plus			
27/59	Under/Over Voltage		
32/55	Directional Power/Power Factor		
47	Negative Phase Sequence Overvoltage		
60CTS	Enhanced CT Supervision		
60VTS	VT Supervision		
67/50, 67/51	Directional Overcurrent		
67G/N	Directional Earth Fault		
81	Frequency		

Additional Functionality

No additional functionality	15	A
-----------------------------	----	---

Spare

	16	0
--	----	---

Notes

- 1) E4 case is standard, E6 case is required if IEC61850 and/or Temperature Input options are ordered
- 2) Applicable to non-integral Temperature Input variants. Requires selection of Protocol - Modbus RTD Client, which precludes use of system comms.